



Portable Acoustic-Based Weapon Testing and Training

Tactical Acoustic Real-time Geolocation and Training System



Trident Research LLC
2809 Longhorn Blvd
Austin, Texas 78758
USA



Trident Research is a leading manufacturer of portable acoustic-based instrumentation for land or sea weapon testing and training

For water based testing and training, there is no capability less expensive, faster, or more accurate than Trident's Tactical Acoustic Real-time Geo-location and Training (TARGT™)



TARGET™ Concept of Operations

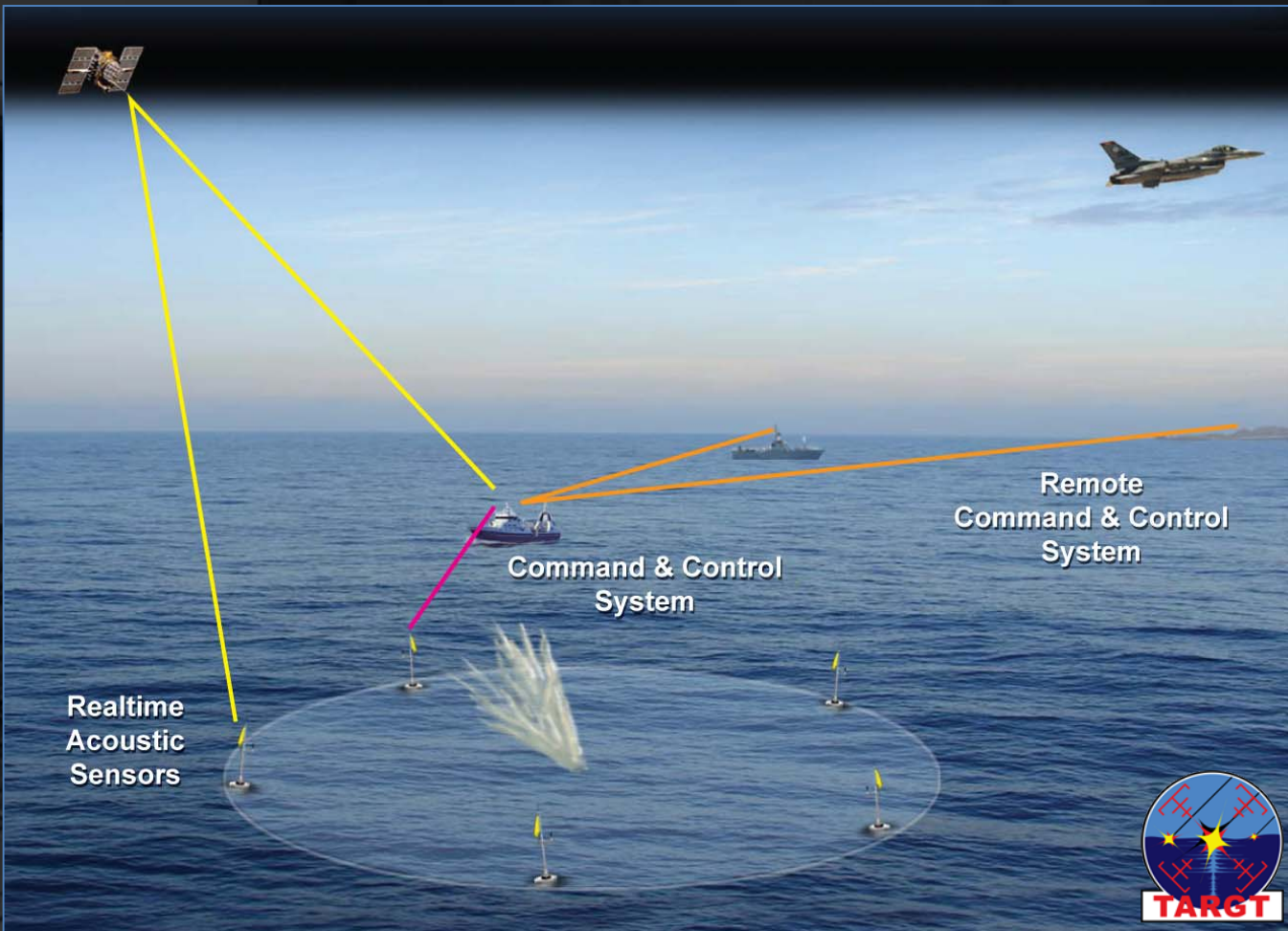

A distributed array of portable remote sensors provides meter-level real-time scoring of single and multiple simultaneous surface impact munitions.

TARGT™ Components

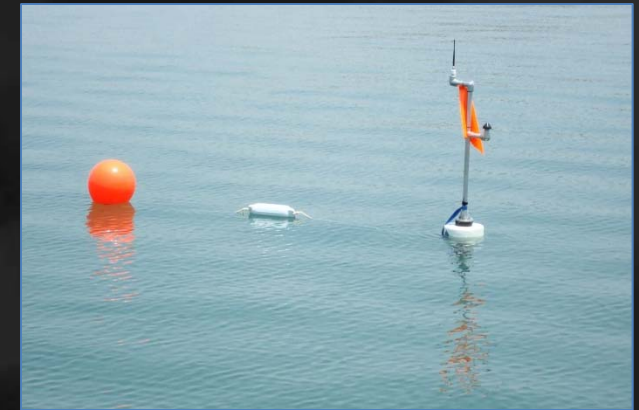
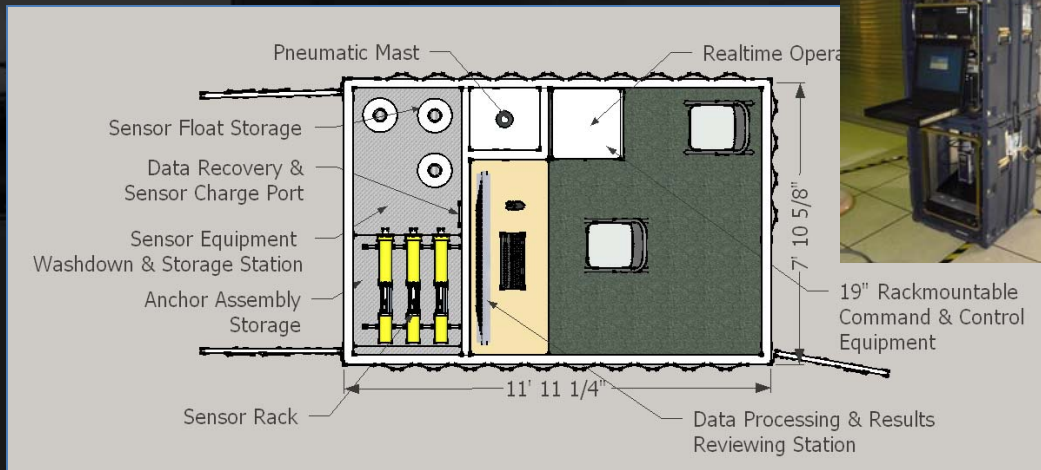

Instrumentation Shelter

Real-time Sensor



Remote Command and Control System

TARGET™ Components Description



Instrumentation Shelter – local command and control system which supports storage, transportation, deployment, health monitoring, and both real-time and post mission data processing.

Real-time Sensor – man-portable sensor deployed in a network of 8-12 units in the test or training area

Remote Command and Control System – a remote display, monitoring, and secondary command and control station often located on shore or on an additional support vessel to provide near real-time feedback

Operations Connectivity



- The TARGT system is a fully networked system that utilizes standard COTS technologies to interconnect the subsystems.
- The Realtime Sensors operate over 900 MHz spread spectrum radios with a demonstrated range of 6+ km and the ability to support up to 15 sensors simultaneously.
- The system can be augmented with a single high gain antenna to extend the operational range to 20km.

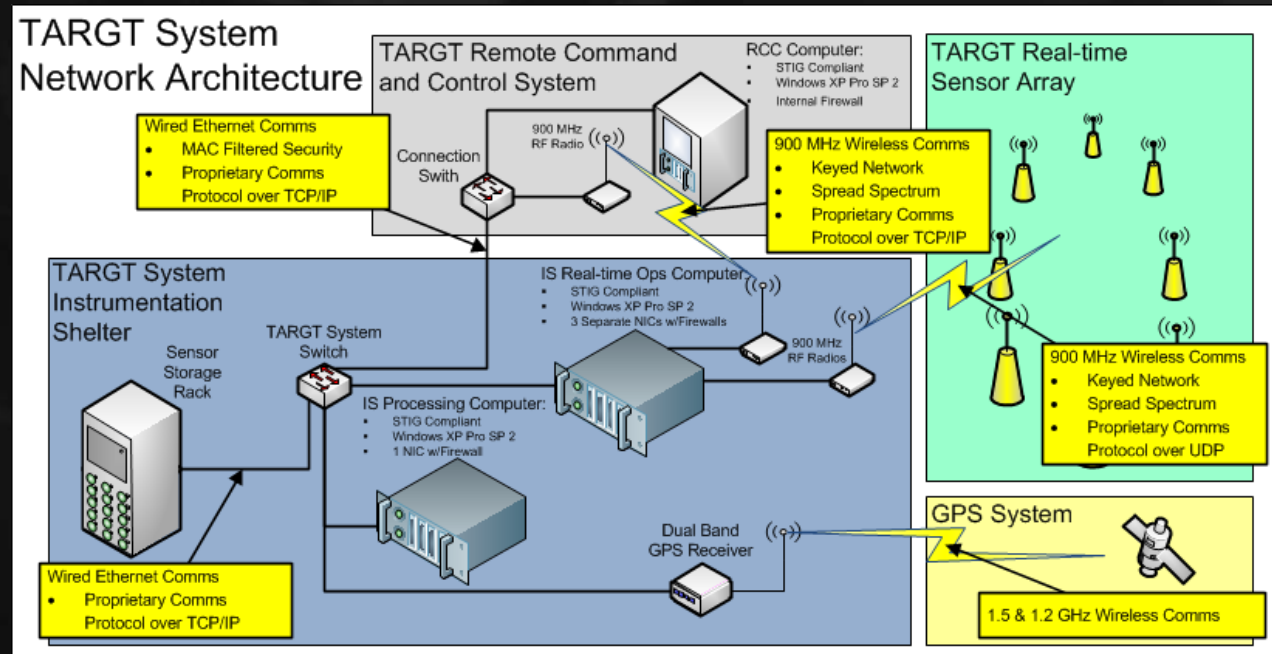

TARGET™ C&C Standard Instrumentation Shelter



Trident integrated the C&C into a portable shelter that also provides for system transportation. All functions of the system, including both real-time and post mission, can be conducted from the 12' ISO.

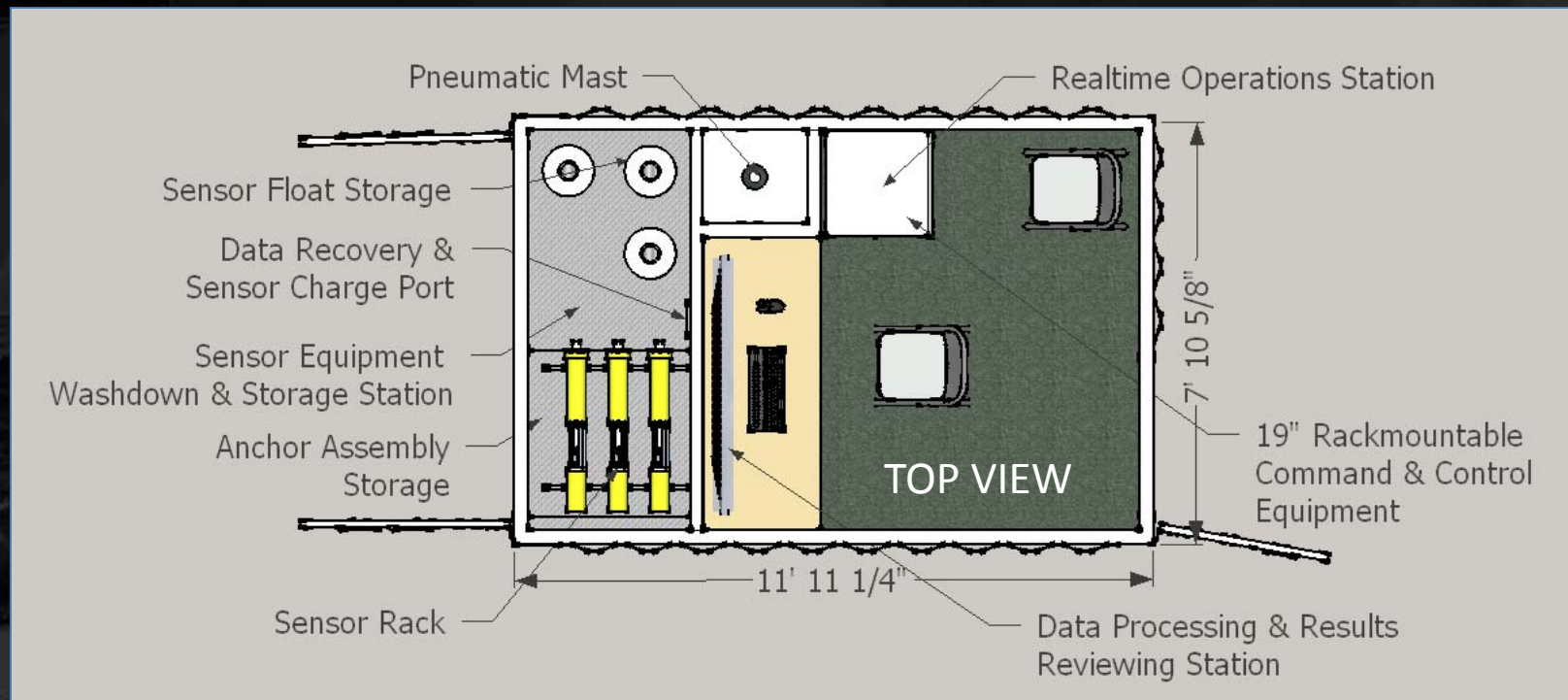

TARGT™ C&C Adaptability

Trident has deployed TARGT™ and other similar C&C products in several form factors, from a single laptop to a full ISO container.

Depending on operational needs and customer requirements, the TARGT™ C&C capability can be permanently installed onboard ship or configured in a variety of “roll on / roll off” form factors.

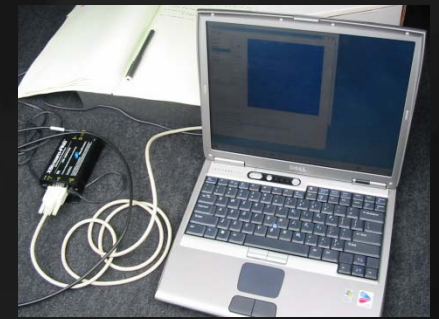

TARGET™ Real-time Sensor



Designed from the ground up by Trident, including all mechanicals, electronics boards, and firmware, the Real-time Sensor is deployable in both drifting and moored configurations

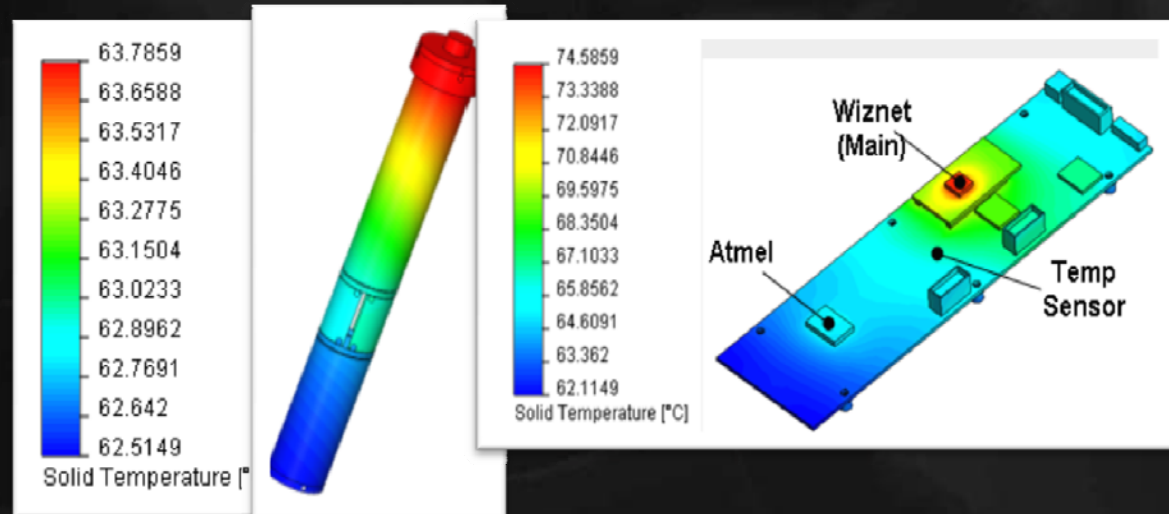

The electronics package is installed in both the TARGET™ and TRACS™ products and has been in operation since its original fielding in March 2009

TARGET™ Real-time Sensor



Lid, Connectors
& Switches

- Anodized
- 6061 Aluminum Alloy
- Environmentally Sealed

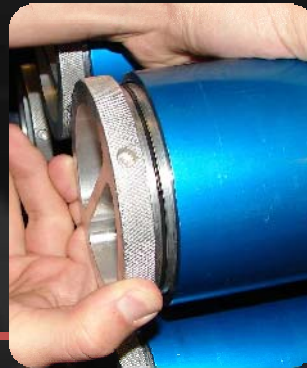

Flotation
Collar

Battery
Plug



RF Mast

Electrical
Hull

Battery
Hull

TARGET™ Remote C&C



- The RCC is connected to the IS over one of three link mediums; fiber optic, direct Ethernet, or RF.
- The RCC provides the system with the ability to control all system operations, or simply view real-time results at a remote location.
- The RCC is composed of a computer terminal and the interface hardware to support any of the available connection mediums.

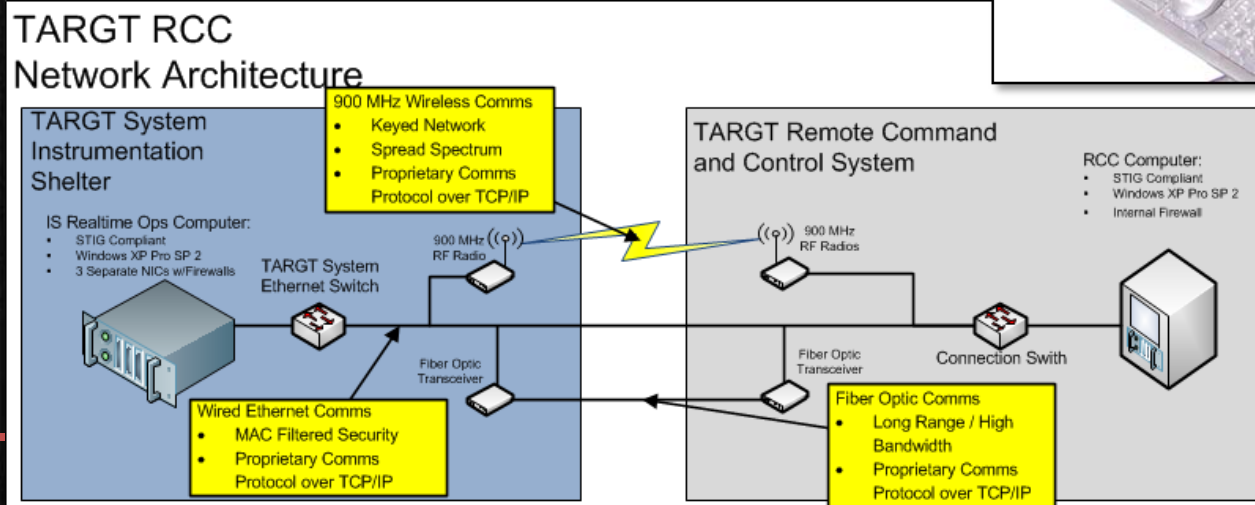

TARGT™ Software



TARGTControl™ – real-time software for monitoring system status, sensor health, and real-time capturing of acoustic events

BackPlot™ – real-time and post-mission processing engine for refined processing and analysis of acoustic events

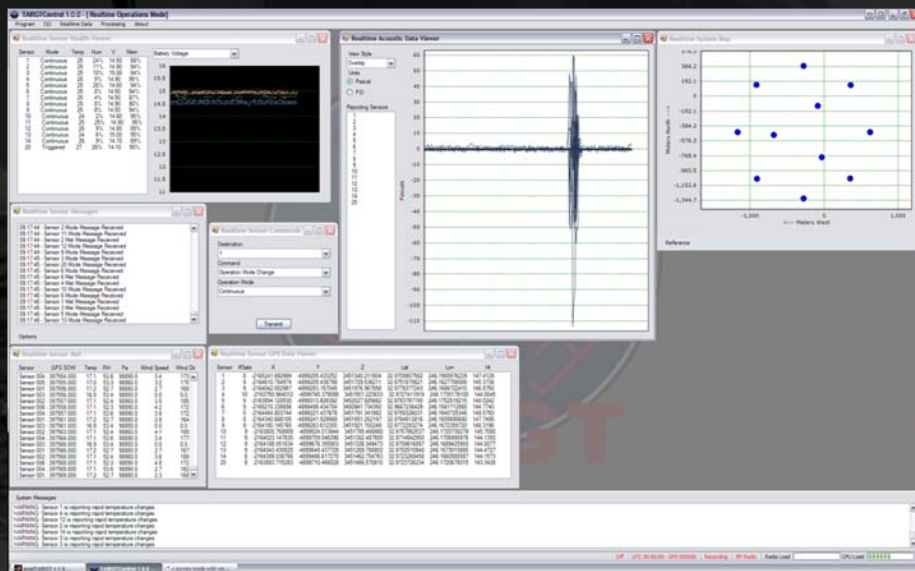

TARGTControl™

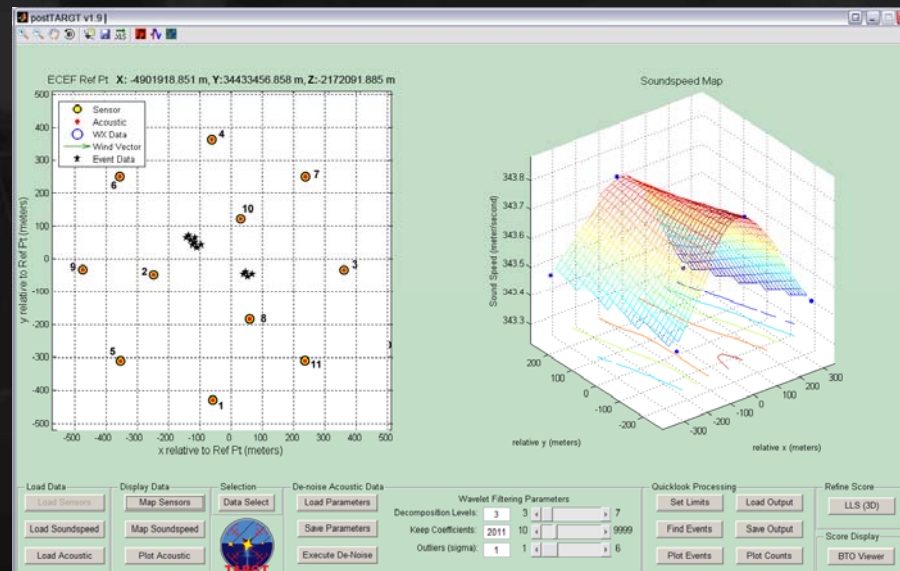

BackPlot™

TARGTControl™ Software



The user friendly GUI provides a simple but robust and user-tailorable interface with built-in training videos and manuals for operations, data processing, and in-field system troubleshooting.

Realtime Sensor Health Viewer

Sensor	Mode	Temp	Hum	V	Men
1	Continuous	25	24%	14.50	88%
2	Continuous	25	11%	14.50	84%
3	Continuous	25	5%	14.50	84%
4	Continuous	25	9%	14.50	85%
5	Continuous	25	28%	14.50	84%
6	Continuous	25	8%	14.50	84%
7	Continuous	25	4%	14.50	84%
8	Continuous	25	8%	14.50	80%
9	Continuous	25	8%	14.50	94%
10	Continuous	24	2%	14.50	95%
11	Continuous	25	25%	14.50	95%
12	Continuous	24	2%	14.50	95%
13	Continuous	24	8%	15.50	95%
14	Continuous	26	9%	14.70	85%
20	Triggered	27	26%	14.10	90%

Realtime Acoustic Data Viewer

View Style: Overlaid
Units: Pascal
Reporting Sensors: 1, 2, 3, 4, 5, 6, 7, 8, 9, 10, 11, 12, 13, 14, 20

Realtime System Map

Meters Depth vs Meters West

Realtime Sensor Messages

09:17:44 - Sensor 11 Mode Message Received
09:17:44 - Sensor 12 Mode Message Received
09:17:44 - Sensor 13 Mode Message Received
09:17:45 - Sensor 1 Mode Message Received
09:17:45 - Sensor 2 Mode Message Received
09:17:45 - Sensor 3 Mode Message Received
09:17:45 - Sensor 4 Mode Message Received
09:17:45 - Sensor 5 Mode Message Received
09:17:45 - Sensor 6 Mode Message Received
09:17:45 - Sensor 7 Mode Message Received
09:17:45 - Sensor 8 Mode Message Received
09:17:45 - Sensor 9 Mode Message Received
09:17:45 - Sensor 10 Mode Message Received
09:17:45 - Sensor 1 Mode Message Received
09:17:45 - Sensor 2 Mode Message Received
09:17:45 - Sensor 3 Mode Message Received

Realtime Sensor Commands

Destination: 1
Command: Operation Mode Change
Operation Mode: Continuous

Realtime Sensor Alert

Sensor	GPS SOW	Temp	RH	Pa	Wind Speed	Wind Dir
Sensor 004	397954.000	17.1	53.6	88880.0	3.4	173
Sensor 005	397955.000	17.0	53.3	88880.0	3.2	173
Sensor 001	397956.000	17.2	52.7	88880.0	2.7	169
Sensor 002	397956.000	16.9	53.4	88880.0	0.0	0
Sensor 002	397957.000	17.1	52.4	88880.0	3.5	185
Sensor 002	397958.000	17.2	52.7	88880.0	4.2	172
Sensor 004	397957.000	17.1	53.6	88880.0	3.8	172
Sensor 002	397960.000	17.2	52.7	88880.0	2.8	184
Sensor 003	397961.000	16.9	53.4	88880.0	0.0	0
Sensor 002	397962.000	17.1	53.4	88880.0	4.1	189
Sensor 004	397964.000	17.1	53.6	88880.0	3.4	177
Sensor 002	397966.000	16.9	53.4	88880.0	0.0	0
Sensor 001	397966.000	17.2	52.7	88880.0	2.7	167
Sensor 002	397968.000	17.1	52.4	88880.0	3.6	188
Sensor 004	397968.000	17.1	53.3	88880.0	4.8	172
Sensor 004	397969.000	17.1	53.6	88880.0	2.7	182
Sensor 001	397969.000	17.2	52.7	88880.0	2.3	169

Realtime Sensor GPS Data Viewer

Sensor	zData	x	y	z	Lat	Lon	HE
1	8	-2164241.692099	-4899208.432052	3451346.211804	32.970907832	246.1658976229	147.4129
2	9	-2164810.784874	-4899205.438799	3451729.538211	32.9781870621	246.1627790589	146.3728
3	9	-2164242.002087	-4899203.107445	3451576.967808	32.9732777043	246.1685224415	146.8760
4	10	-2163790.964012	-4899743.379099	3451001.223633	32.972111919	246.1705179100	144.0045
5	9	-2163284.205930	-4899113.295392	3452007.925662	32.9787879102	246.1702919215	148.0242
6	9	-2165210.330506	-4899498.434704	3450941.744200	32.9687236429	246.1681718280	144.7742
7	5	-2164484.803744	-4899201.437878	3451791.341883	32.9783282021	246.1640725346	148.5793
8	9	-2165240.688005	-4899241.629068	3451681.026197	32.9681189146	246.1656699660	147.5495
9	9	-2164180.145765	-4899263.612200	3451821.950249	32.9722932714	246.1672269720	148.3196
10	9	-2163000.789009	-4899264.018844	3451785.469860	32.9787962617	246.1720788279	148.7000
11	9	-2164023.147835	-4899708.546396	3451382.487800	32.9748429650	246.1708899576	144.1390
12	9	-2164188.015134	-4899676.359003	3451326.348470	32.9708160597	246.1684429900	148.8077
13	9	-2164343.430205	-4899648.437729	3451293.788802	32.9702510848	246.1679015885	144.4127
14	8	-2164399.038796	-4899486.617270	3451482.754763	32.9723268482	246.1680260507	144.1573
20	9	-2163883.715283	-4899710.466029	3451486.570810	32.9723746204	246.1700879319	143.3428

System Messages

WARNING: Sensor 1 is reporting rapid temperature changes
WARNING: Sensor 12 is reporting rapid temperature changes
WARNING: Sensor 13 is reporting rapid temperature changes
WARNING: Sensor 2 is reporting rapid temperature changes
WARNING: Sensor 14 is reporting rapid temperature changes
WARNING: Sensor 3 is reporting rapid temperature changes
WARNING: Sensor 2 is reporting rapid temperature changes

BackPlot™ Software Sample Scoring Output



The real-time software provides <1.5 meter 2D results in seconds and <1 meter 2D results post-mission.

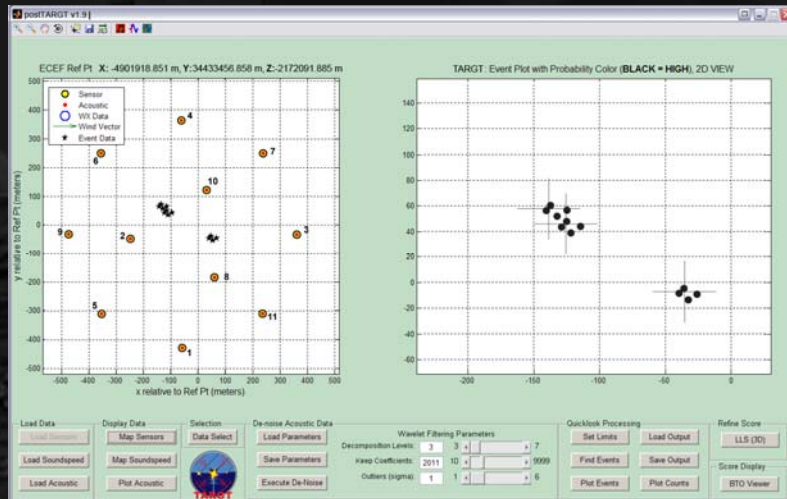

SENSOR MAPS

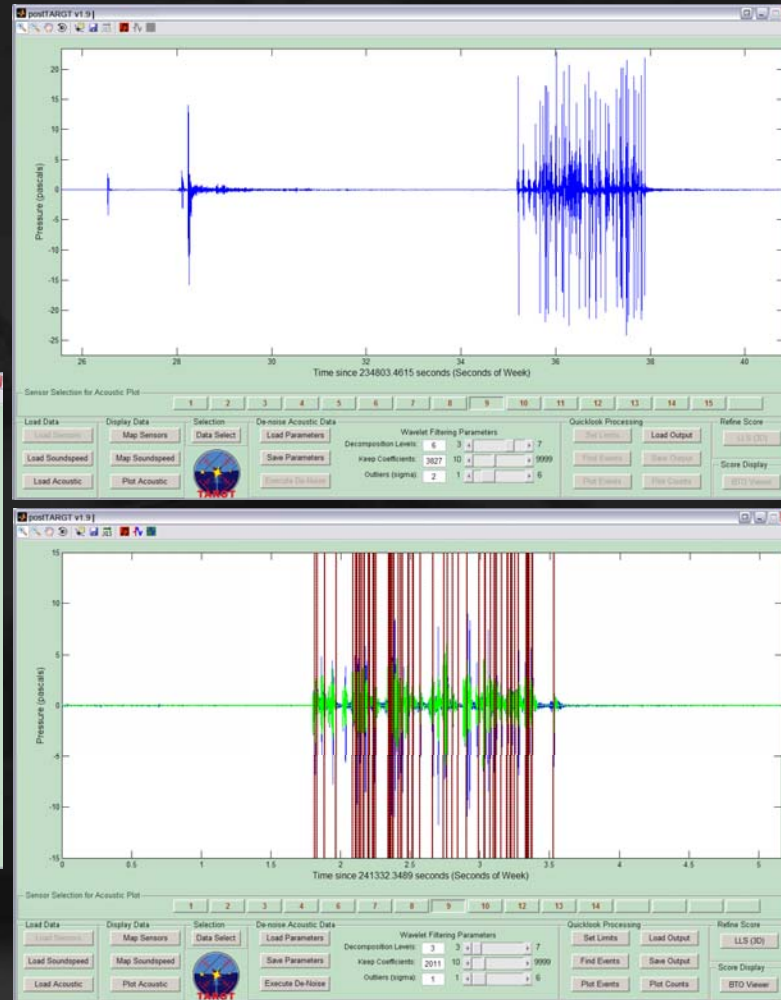

ACOUSTIC SIGNATURE ANALYSIS

WAVELET FILTERING ANALYSIS

TARGT Scoring Error Budget



TARGT Scoring Uncertainty (50% CEP)	Realtime (m)	Post-Process (m)
Sensor Position (GPS)	0.80	0.30
Hydrophone Scope (misalignment)	0.25	0.25
Propagation Error (acoustic)	0.80	0.60
Aggregate Random Error	1.16	0.72
Reference Error (common mode/bias)	0.30	0.20
Solution Uncertainty	1.46	0.92